

# Condor

2019

Luc Goldstein  
BASc Integrated Engineering Student,  
Electrical and Mechanical specialization  
778-683-7653 | luc.goldstein@gmail.com

As a direct response to the 2019 AUVSI SUAS challenge, Condor was built to complete a long distance payload drop with high positional accuracy.

Speed, high payload capacity, and endurance allowed Condor to successfully complete the given mission with excellent precision.

Top speed – 120 km/h

MTOW – 12kg

Wing Span – 1500mm

Max elec Power – 7600W

My challenges included building a very stiff but light frame that was not susceptible to vibration or bending. Large and thin carbon fiber tubes paired with a simple sandwiched center plate design ensured all specs were met. Analysis showed that round tubes had the best stiffness to weight ratio over other easily available tube shapes.

I performed extensive testing on the power system to verify over current and over temperature limits were not exceeded during cruise flight or higher power maneuvers. Careful battery, motor, and propeller optimization was required to ensure distance, speed, and payload requirements were met.



# Condor Design Details

2018/19

Luc Goldstein  
BASc Integrated Engineering Student,  
Electrical and Mechanical specialization  
778-683-7653 | luc.goldstein@gmail.com

## Power System Optimization:

Given limited access to testing equipment, I started by using a dynamometer and logging ESC (electronic speed controller) to verify manufacturer specs and thrust/RPM correlation. This allowed me to do further tests with out the dynamometer and at thrust levels beyond the dynamometer capacity.

FOC (field oriented control) and BLDC (Brushless DC) ESCs were tested primarily for efficiency. While no significant efficiency difference was measured, we chose the FOC controllers for the improved throttle response.

Finally, different motors were tested to identify the best optimization of cruise power, thermal limits, and efficiency.

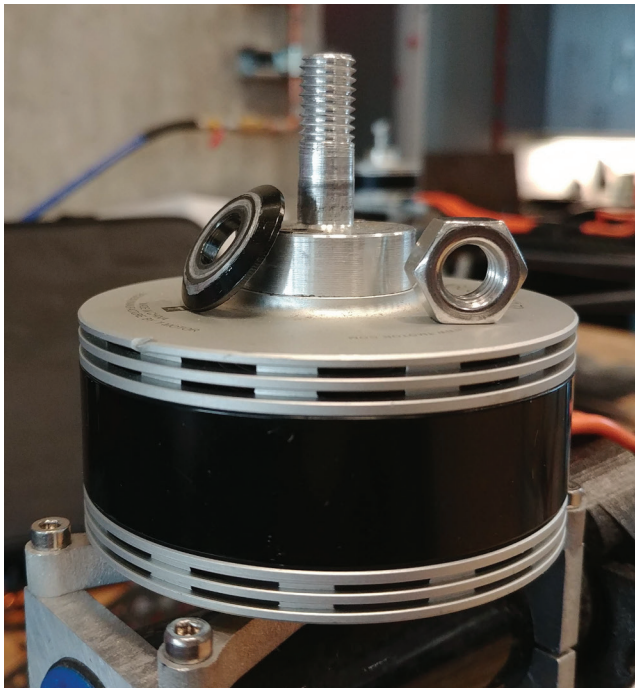

## Custom Prop Mounts:

Unfortunately no off the shelf propeller mount fit our choice of motor and propeller.

Given the team's time constraints, I quickly designed suitable mounts and machined them with the available mill and lathe. Particular care was put into making sure the mounts were perfectly balanced and the left and right hand threads were cut cleanly. This allowed our development and testing process minimal down time.

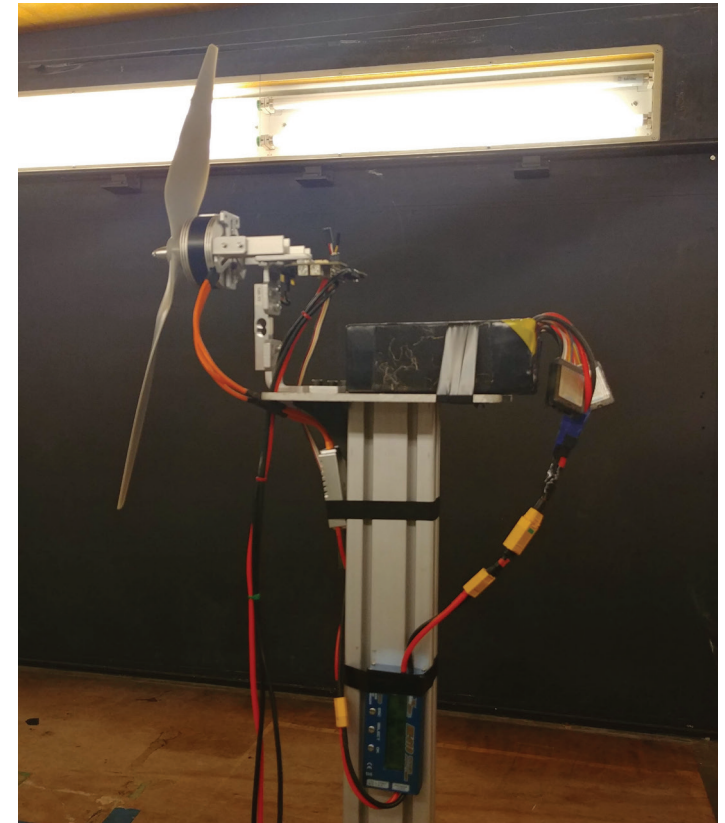



# Thermal Model of Brushless Motor

2018

Luc Goldstein  
BASc Integrated Engineering Student,  
Electrical and Mechanical specialization  
778-683-7653 | luc.goldstein@gmail.com

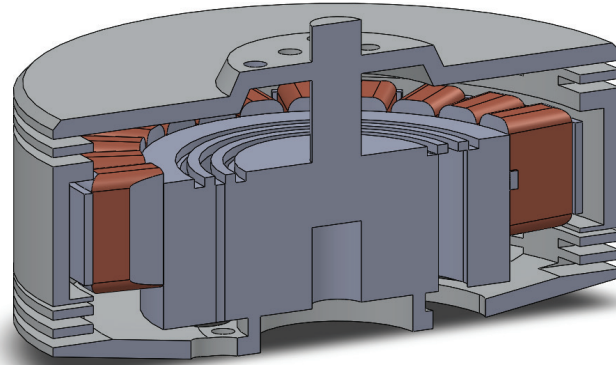

As an extra credit project I decided to explore the thermal impacts of operating a motor at it's max rated load. It was of particular interest as this motor was planned to run at the edge of their rated thermal limits for my design team's aircraft, "Condor".

- Modeled representative internal motor geometry.
- Simulated air flow and heat transfer in ANSYS to find max temps.
- Validated simulations with thermal camera on bench tests that showed comparable results.

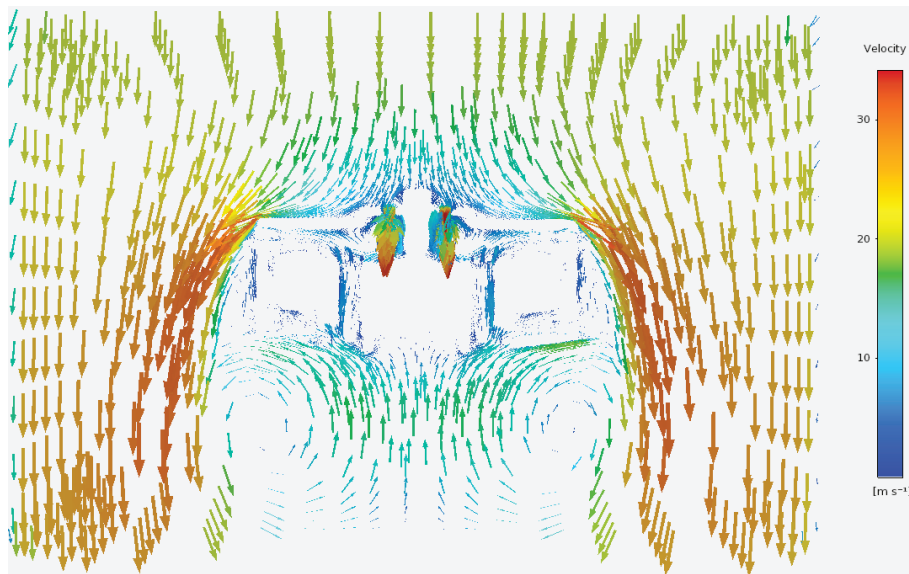

Visualization of airflow through and around motor. Of note is the upward airflow through the bottom of the motor over the coils

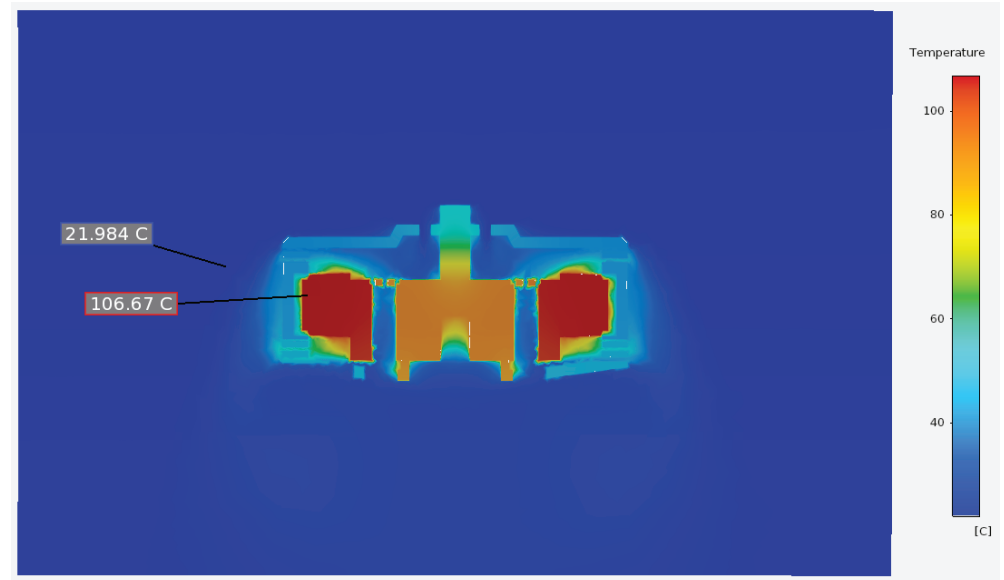

Thermal heat map showing the very hot coils and the heat transfer through the motor.

# The SNOWZY

2018

Luc Goldstein  
BAsC Integrated Engineering Student,  
Electrical and Mechanical specialization  
778-683-7653 | luc.goldstein@gmail.com

As part of a second year design course, I worked on designing and building a heated phone case to extend battery life in cold weather. Lithium batteries performance significantly degrades at low temps so it is desirable to keep the device temperature above 10°C. We built a heated case allowing sustained use of the phone in sub-zero conditions. We proved an extension in battery life of up to 2x while using the case

## Personal Contributions:

- Developed an accompanying Android app with java to communicate internal phone temperature to the case and display diagnostic info to the user
- Created detailed CAD renders for presentation
- Estimated heat loss from phone and thermal conductivities to approximate the required heater size.
- Designed switching and battery charging circuit along with the nichrome wire heater.

## FEATURES & COMPONENTS

### Structural Case

- Provides extra insulation to front screen
- Structure for holding device together

### External Device Battery

- Powers the microcontroller and heating elements

### Insulation

- Ceramic wool
- Locks in heat and serves as fire deterrent

### Recycled Casing

- Secures components to structural case
- Crafted from plastic bags

### Microcontroller

- Bluno Beetle
- Serves as bluetooth connection between phone application and heating wires
- Integrated with user interface LEDs

### Heating Wires

- 36 gauge Nichrome wire

### Thermal Pads

- Sandwiches the Nichrome wire
- Disperses thermal energy evenly over phone backing



(Actual App)

# The Gimbal

2018

Luc Goldstein  
BASc Integrated Engineering Student,  
Electrical and Mechanical specialization  
778-683-7653 | luc.goldstein@gmail.com

While managing the aircraft build team I personally took on the detailed design of a low profile, light weight gimbal for our mapping camera. The gimbal was to fit into the bottom of our fixed wing aircraft and valued low weight and low profile design over smooth motion.

- Clean sheet design
- Optimized for 3D printing and to be as light as possible
- Successfully designed and printed to be under 100g
- Installed into aircraft and proved working stabilization

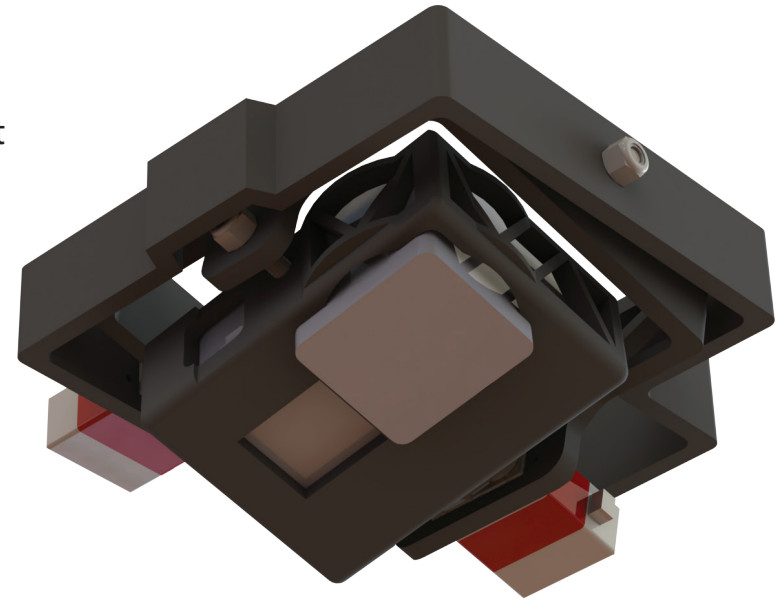

Gimbal installed in fuselage of our competition aircraft

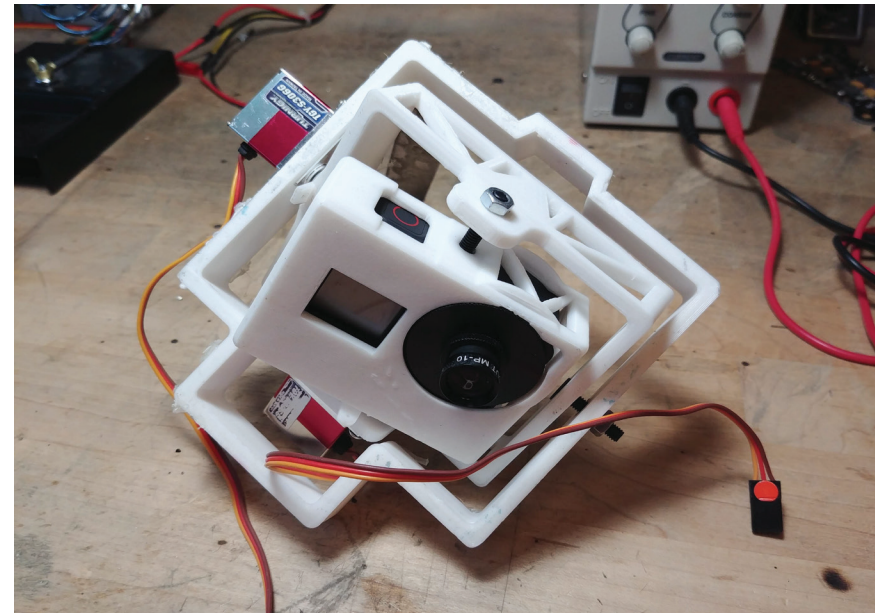

Final Gimbal with Modified GoPro Hero 6 installed after removal from competition aircraft



# Evo Car Share Roof Rack Protection 2019

Luc Goldstein  
BASc Integrated Engineering Student,  
Electrical and Mechanical specialization  
778-683-7653 | luc.goldstein@gmail.com

## The Problem:

Evo Car Share, a local car share company in Vancouver, defines their brand partially through the roof mounted bike racks they include on all their cars. This also presents a problem of customers accidentally driving into underground parkades with a bike on the roof and causing significant damage to their cars. My capstone group was tasked with finding a solution to minimize the economic strain of this problem.

## The Solution:

- A location based warning system gives an alert to the driver when they are about to drive into a low clearance parkade with a bike on the roof.
- I spearheaded the design and implementation of an embedded GPS system that ran on a raspberry pi to constantly read the current GPS location and compass heading, while comparing to a database of know parkades' entrances.
- The solution was tested extensively both through simulation and then implemented into multiple Evo fleet cars for client testing.
- Pulled 12v power from vehicle fuse box and incorporated power regulation for a fully integrated system
- Worked with EVO to develop an installation system to easily and quickly install systems into their 1500+ vehicle fleet

## The Result:

After completion of the class, a contract was signed and three full systems were delivered and installed in EVO cars for final validation.



# Battery Discharge PCB

2020

Luc Goldstein  
BASc Integrated Engineering Student,  
Electrical and Mechanical specialization  
778-683-7653 | luc.goldstein@gmail.com

In an effort to find new battery pack options for my design team's drones I wanted to investigate the new 40T 2170 Lion cells from Samsung. I decided to design and build a custom PCB to discharge a single cell with a constant current load and log it's discharge voltage curve. This is of interest because our aircraft are fairly demanding in power requirements and we want to minimize any voltage sag. Unfortunately it was found that under high loads (>20A) the 40T suffers from significant voltage sag.

- Hand soldered SMD components
- On board voltage and current sensing up to 20A
- Adjustable constant current load 0-20A
- Calculated heat dissipation/cooling requirements
- Scripted python module to log and visualize voltage vs SoC plots
- Designed custom 2170 cell holder with nickel cell contact tabs

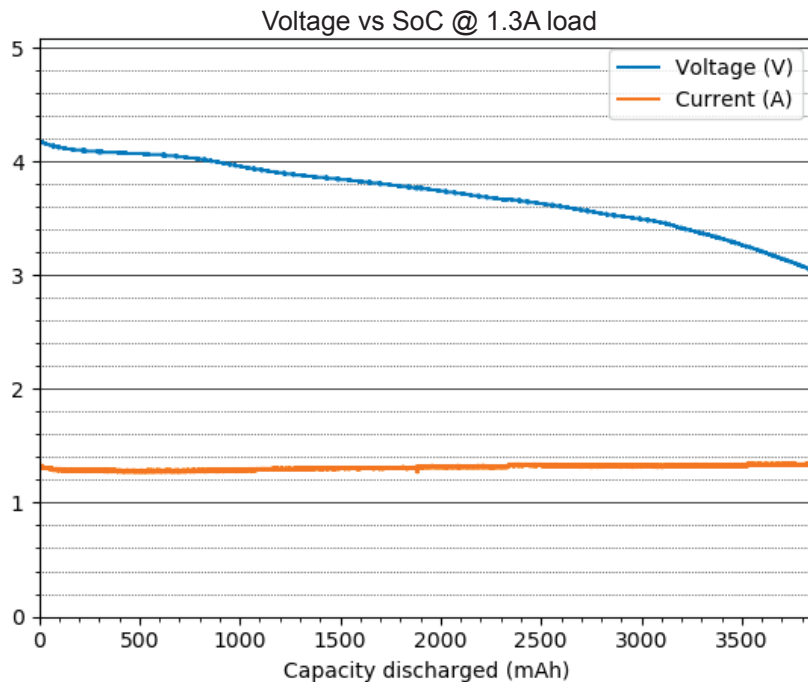
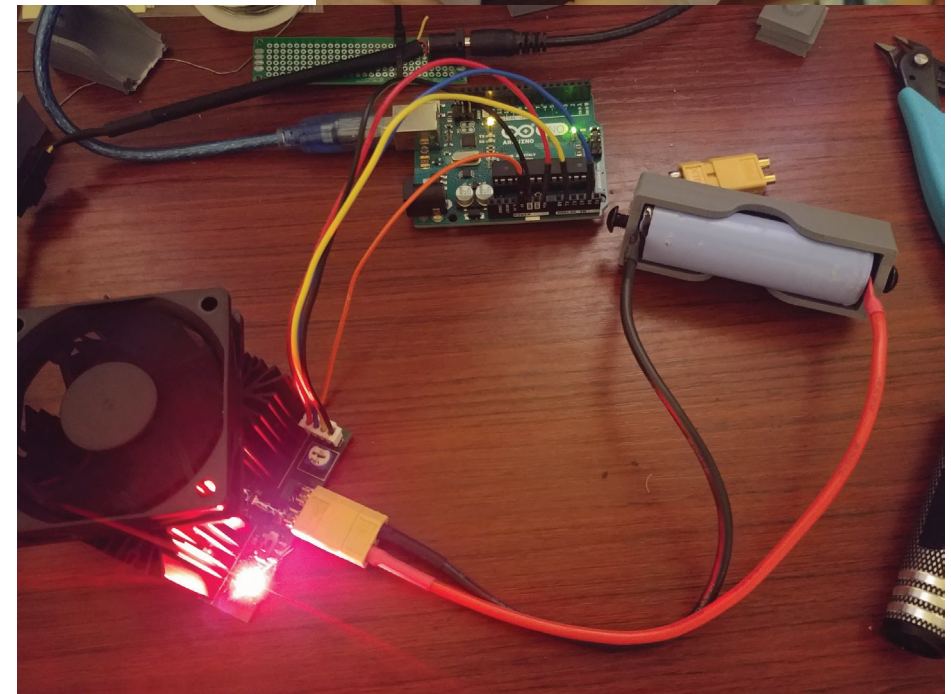
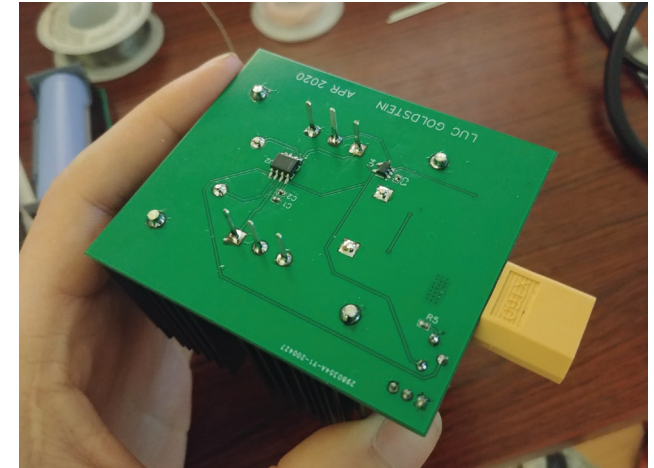



My time at Tesla was a constant thrill of catching up and marching forward to meet the demands of a company paving the way for electric vehicles.

- Designed and worked on ~12 injection molded parts, working from concept to prototype, and even to full production for some.
- Participated in prototype battery pack builds offering suggestions for improvement on problematic components
- Facilitated new product integration into factory production with new assembly fixtures
- Spent weeks running and modifying tests to verify high risk prototype designs under wide temperature and pressure ranges

